

ECOWISE DUO™ 30/1

**The Ultimate
Smart Grid
Solution**

INSTRUCTION MANUAL

9310-0004 Rev B
Effective: September, 2011



Welcome

Congratulations on selecting the ECOWISE DUO™ unit to manage your energy supply needs. ECOWISE DUO™ units optimize and stabilize the voltage used at the residential level, thereby helping to protect electrical equipment, and more importantly, improving the electrical service to consumers.

For more information about this and other products from THE TECHNOWISE GROUP® please visit our website at: www.technowisegroup.com

How it Works

The ECOWISE DUO™ unit modifies and reconstructs the AC waveforms at a more efficient power level without adding undesirable harmonic distortion. In extreme cases where the delivered voltage falls below the minimum required level, the ECOWISE DUO™ unit solves this problem by boosting and stabilizing the incoming voltage such as to allow the voltage to be at an optimal level. Unlike voltage boosters that are available for single appliances in certain areas of the world, the boost section of the ECOWISE DUO™ maintains the voltage at a minimum and optimal level for the whole house. Not only does the ECOWISE DUO™ unit improve the quality of the electrical service for the consumer, it also allows the removal of unsightly voltage boosters from the vicinity of appliances so equipped. Therefore, the ECOWISE DUO™ unit functions as a “Whole House Stabilizer.”

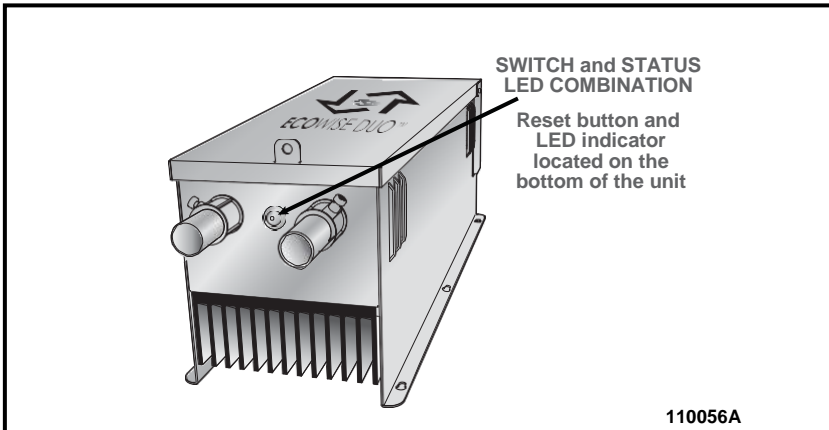

Figure 1. Reset/Status LED Switch Combination

Before Installing the Unit

Before installing the ECOWISE DUO™ unit, the following actions must be taken into account to validate the warranty:

- Use a qualified licensed electrical contractor.
- Have the ECOWISE DUO™ Site Survey completed and available.
- Establish adequate grounding for the home or commercial establishment.

A qualified licensed electrical contractor will set up a pre-installation site survey to evaluate the maximum power of the home or commercial establishment and the maximum power the utility company is delivering. This survey will help determine the correct ECOWISE DUO™ model.

Next, the survey will determine if the proper grounding exists for the home or commercial establishment. The ECOWISE DUO™ unit should not be installed without proper grounding present.

Finally, for ease of installation and safety, the ECOWISE DUO™ unit needs to be installed only by a qualified licensed electrician and according to the local electrical codes.

Without the proper grounding in the home or commercial establishment and the use of a non-qualified licensed electrician, the warranty for the ECOWISE DUO™ unit will be void.



Ensure there is a proper ground connection in the home or commercial establishment before installation.



ECOWISE DUO™ units must only be installed by a qualified licensed electrician. Failure to follow instructions can cause electrocution, severe injury, death or property damage.

Installation

Once the pre-installation process is completed, it is time to install the ECOWISE DUO™ unit. Figure 2 shows a typical installation.

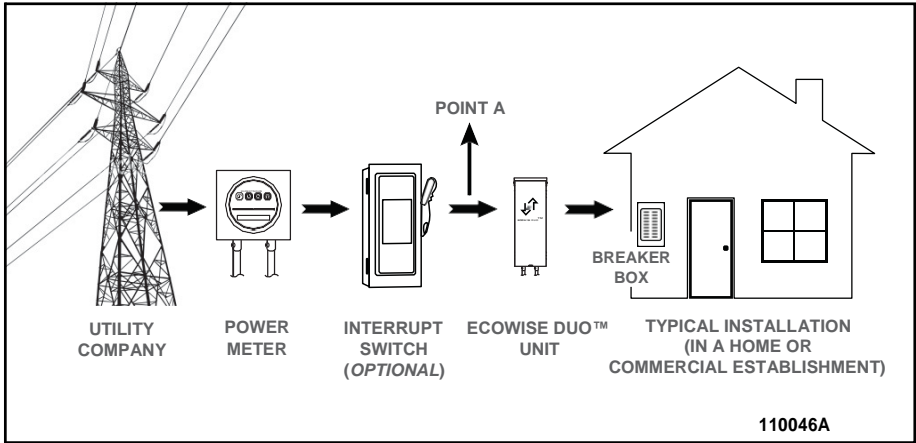

Figure 2. A Typical Installation

Installation Tools and Supplies

Installation of the ECOWISE DUO™ unit requires a few tools and supplies. Your electrical contractor will need to have these items:

- Level
- The cable size must be at least 10 AWG copper wire (5.3 mm²) or 8 AWG aluminum wire (8.4 mm²).
- Drill and drill bits (either 1/4" size or 1/2" hammer drill size depending on the surface material)
- Multi-Meter
- Phillips screw driver
- Blade screw driver
- Wire cutter
- Wire stripper
- #10 screws

All mounting hardware and electrical connectors need to be supplied by the installer since installation supplies will vary by each country according to their electrical codes.

Step 1.

Power to the home or commercial establishment must be turned off prior to installation. Turn power off at the main disconnect switch. Make sure power is completely turned off at Point A (Refer to Figure 2). This can be accomplished by turning off the optional interrupt switch (Figure 2), or by contacting your utility company to disconnect the power. Use a multi-meter to verify that there is no voltage present in the home.



ECOWISE DUO™ units must only be installed by a qualified licensed electrician. Failure to follow instructions can cause electrocution, severe injury, death or property damage.

Step 2.

Refer to the ECOWISE DUO™ Site Survey to identify the appropriate location where the ECOWISE DUO™ unit will be mounted.

Remove the Placement Template from the packing box and attach tape to the corners to secure it to the surface.

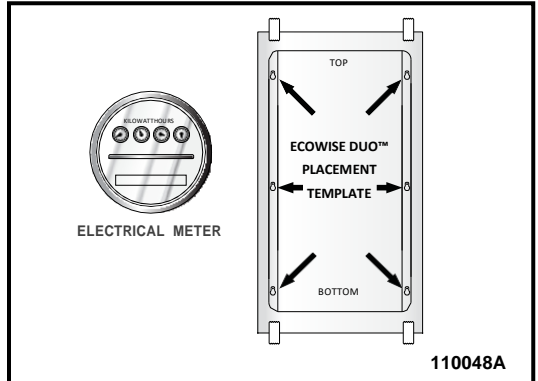

In this example, the Interrupt switch is not present.

Step 3.

Use a level to ensure that the template is level before you begin to locate and drill the screw holes.

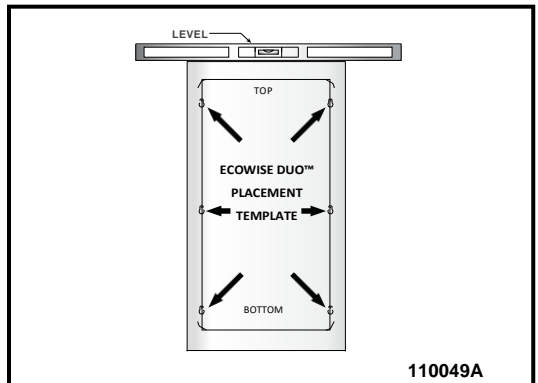

Step 4.

Drill the holes at the six (6) locations marked on the template.

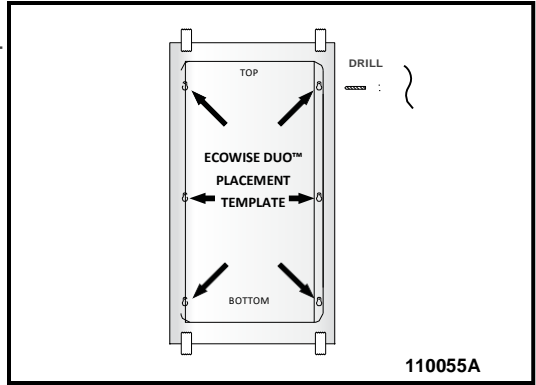

Step 5.

Position the unit over the screw holes and fasten the screws to secure the unit to the surface.

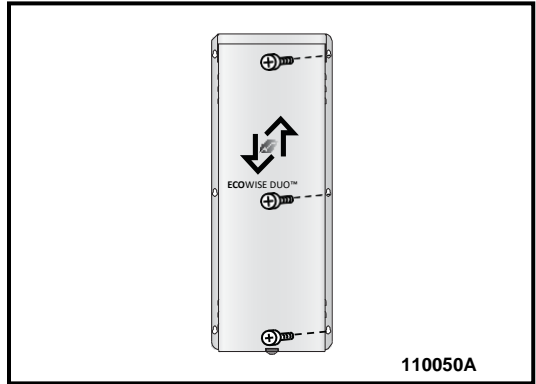

Step 6.

Open the cover of the unit and install conduit pipe adapters in the holes at the bottom and tighten fully.

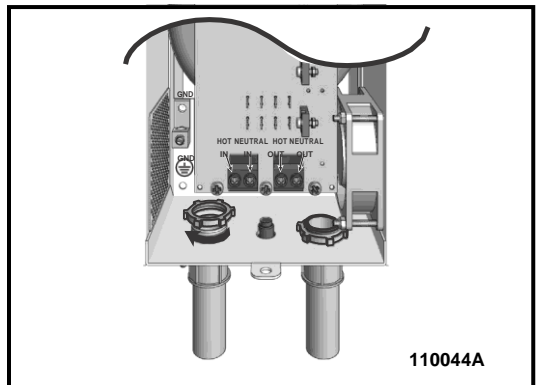



Make sure power has been turned off at Point A (Figure 2) and the home or commercial establishment is de-energized.

Step 7.

Use conduit pipes and connectors to run wires from the interrupt switch (if present) or electrical meter through the conduit to the ECOWISE DUO™ unit (left side). Locate the ground wire as shown in this example.

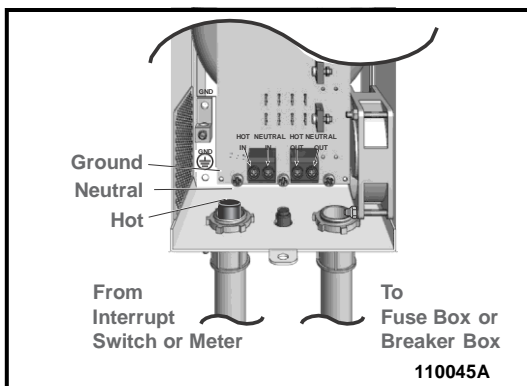

Step 8.

Use conduit pipes and connectors to run wires from the fuse box or breaker box through the conduit to the ECOWISE DUO™ unit (right side). Locate the ground wire as shown in this example.

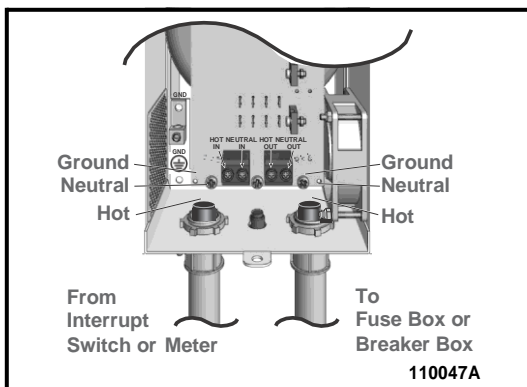

Step 9.

Measure, cut, and strip the three (3) wires that pass between the interrupt switch (if present) or electrical meter and the three (3) wires that pass between fuse box or circuit breaker panel to the ECOWISE DUO™ unit.

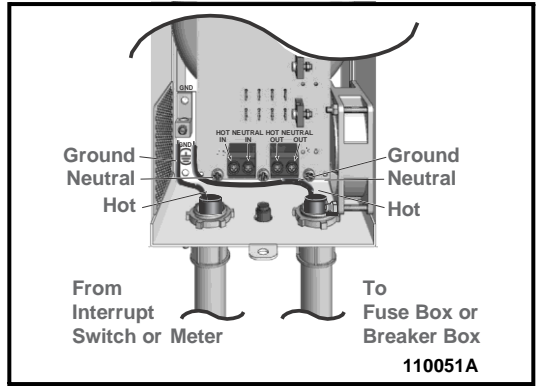

Step 10.

Insert the ground wires into the ground lug and tighten fully to 25 in. lbs.

NOTE: Ground wires must be properly used for safety reasons and for the warranty of the ECOWISE DUO™ unit to be effective.

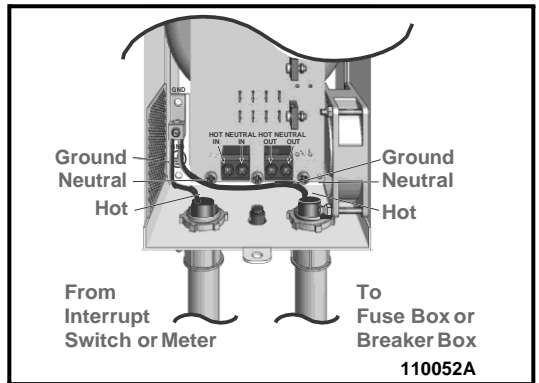

Step 11.

Connect the hot wire from the interrupt switch (if present) or electrical meter to the ECOWISE DUO™ unit's HOT IN and tighten fully to 30 in. lbs. Connect the neutral wire from the interrupt switch or meter to the terminal block of the ECOWISE DUO™ unit's NEUTRAL IN (left side) and tighten fully to 30 in. lbs.

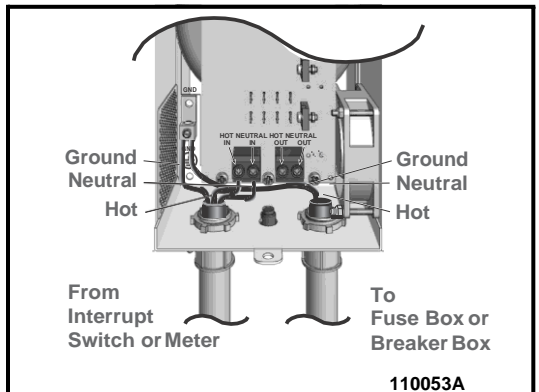

Step 12.

Connect the hot wire from the breaker box or fuse box to the terminal block of the ECOWISE DUO™ unit's HOT OUT and tighten fully to 30 in. lbs. Connect the neutral wire from the fuse box or breaker box to the terminal block of the ECOWISE DUO™ unit's NEUTRAL OUT (right side) and tighten fully to 30 in. lbs.

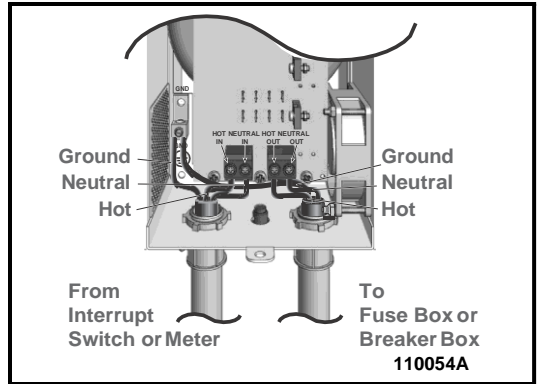

Completing the Installation

After following the proper installation procedures, it is time to apply power back to the home or commercial establishment. Please ensure all the breakers to the loads in the house or commercial establishment are in the OFF position (disconnected). When power is initiated, the green status LED on the ECOWISE DUO™ will blink 9 times and then become a steady green light. Using a multi-meter, verify the input and output voltages on the ECOWISE DUO™. Turn on each breaker one at a time. You will now begin to experience the ECOWISE DUO™ lifestyle of true energysavings.

Troubleshooting

ECOWISE DUO™ has been designed for trouble-free operation. In the unlikely event of a malfunction, please follow the subsequent steps to determine the cause of the failure (See the Troubleshooting Chart on Page 10).

The ECOWISE DUO™ unit has built-in safety features that prevent damage to your appliances such as short circuits, overcurrents, brown outs, etc. The green LED light blinks at certain intervals to indicate the unit's status. The push-button reset switch with an integrated LED located on the bottom of the unit (See Figure 1) continually monitors the unit's status. The reset switch can be used to clear any fault condition once the corrective action has been taken.

Should you ever experience an interruption in your electrical service, always check the breaker box first. A tripped breaker could be the cause of the interruption of power. If none of the breakers are tripped, please look at the LED at the bottom of the unit to see its status. The blinking LED will indicate the problem by the number of blinks as indicated on the Troubleshooting Chart on Page 10.

When power to your home or commercial establishment is interrupted, please note the number of blinks (blinks repeat after a three-second interval), and refer to the Troubleshooting Chart for more information and corrective action. Once you verify the LED status, contact your ECOWISE DUO™ representative to be guided on the best corrective action, or if you have any questions.

TROUBLESHOOTING CHART

Use the chart below to determine a possible malfunction of the ECOWISE DUO™ unit.

LED STATUS	POSSIBLE CAUSES	RESOLUTION
Always on	The unit is operating properly.	N/A
Off	No power is applied to the unit.	Check for local power outages with your utility company.
1 Blink	“Short Circuit” condition	Turn loads completely off by turning off breakers to the house or business and press the reset button to restore. If problem persists, contact your local ECOWISE DUO™ representative.
2 Blinks	“Over Current” condition	Turn loads completely off by turning off breakers to the house or business and press the reset button to restore. If problem persists, contact your local ECOWISE DUO™ representative.
3 Blinks	“Overheating” condition	Turn loads completely off by turning off breakers to the house or business and press the reset button to restore. If problem persists, contact your local ECOWISE DUO™ representative.
4 Blinks	“Extreme Over Current” condition	Turn loads completely off by turning off breakers to the house or business and press the reset button to restore. If problem persists, contact your local ECOWISE DUO™ representative.
5 Blinks	“Invalid Temperature” condition	Contact your local ECOWISE DUO™ representative.
6 Blinks	“Brown Out” (Low Voltage) condition	Contact your utility company to report the low power condition.
7 Blinks	“Load Manager Over Limit” condition	Turn loads completely off by turning off breakers to the house or business and press the reset button to restore. If problem persists, contact your local ECOWISE DUO™ representative.

Warranty Information

he TECHNOWISE Group® warrants for a period of one year from the date of shipment that this product will be free from defects in material and workmanship and will meet published specifications for this product at the time of shipment, assuming normal use and normal operating conditions. THIS WARRANTY IS THE SOLE AND EXCLUSIVE WARRANTY GIVEN BY THE TECHNOWISE GROUP® WITH RESPECT TO THIS PRODUCT AND IS IN LIEU OF AND EXCLUDES ALL OTHER WARRANTIES, EXPRESSED OR IMPLIED, ARISING BY OPERATION OF LAW OR OTHERWISE, INCLUDING WITHOUT LIMITATION, MERCHANTABILITY AND/OR FITNESS FOR A PARTICULAR PURPOSE, WHETHER OR NOT THE PURPOSE OR USE HAS BEEN DISCLOSED TO THE TECHNOWISE GROUP® IN SPECIFICATIONS, DRAWINGS OR OTHERWISE, AND WHETHER OR NOT THIS PRODUCT HAS BEEN SPECIFICALLY DESIGNED AND/OR MANUFACTURED BY THE TECHNOWISE GROUP® FOR A SPECIFIC USE OR PURPOSE OF BUYER/USER.

Disclaimer and Limitation of Liability

THE SOLE AND EXCLUSIVE REMEDY FOR BREACH OF ANY WARRANTY COVERING ANY PRODUCT SOLD BY THE TECHNOWISE GROUP®, INC. IS THE REPAIR, CORRECTION OR REPLACEMENT FOR SUCH PRODUCT. THE TECHNOWISE GROUP® SHALL NOT BE LIABLE FOR DAMAGES CAUSED BY DELAY IN PERFORMANCE AND THE REMEDY SET FORTH IN THE PREVIOUS SENTENCE IS EXCLUSIVE. IN NO EVENT, REGARDLESS OF THE FORM OF THE CLAIM OR THE CAUSE OF THE ACCIDENT OR THE FAULT OF THE TECHNOWISE GROUP® (WHETHER BASED IN CONTRACT, INFRINGEMENT, NEGLIGENCE, STRICT LIABILITY, OTHER TORT OR OTHERWISE), SHALL THE TECHNOWISE GROUP®'S LIABILITY TO BUYER/USER AND/OR ITS CUSTOMERS EXCEED THE PRICE PAID BY BUYER/USER FOR THE SPECIFIC PRODUCT PROVIDED BY THE TECHNOWISE GROUP® GIVING RISE TO THE CLAIM OR CAUSE OF ACTION. BUYER/USER AGREES THAT IN NO EVENT SHALL THE TECHNOWISE GROUP®'S LIABILITY TO BUYER/USER AND/OR ITS CUSTOMERS INCLUDE INCIDENTAL, CONSEQUENTIAL OR PUNITIVE DAMAGES. The term "consequential damages" shall include, but not be limited to, loss of anticipated profits, business interruption, loss of use, revenue, reputation and data, costs incurred, including without limitation, for capital, fuel, power and loss or damage to property or equipment. It is expressly understood that any technical advice furnished by The TECHNOWISE Group® with respect to the use of the product is given without charge, and The TECHNOWISE Group® assumes no obligation or liability for the advice given, or the results obtained, all such advice being given and accepted at the Buyer's/User's risk.

* THE TECHNOWISE GROUP®, ECOWISE®, and MOTORWISE® are registered marks in the U.S. Patent Office. ECOWISE DUO™ and DEVELOPING GREEN TECHNOLOGIES FOR A BETTER PLANET™ are trademarks in the U.S. of The Powerwise Group, Inc.



**The trademarks THE TECHNOWISE GROUP®,
ECOWISE® and the leaf design are all
registered with the U.S. Patent and
Trademark Offices and are used
under license and are owned by
the PowerWise Group, Inc.**

**Multiple patents pending
in USA and Abroad**

www.technowisegroup.com

**ECOWISE DUO™
EWDH 30/1**

Operating Voltage (AC)	170-260V
Current (continuous)	20A
Max Current (intermittent)	25A